

TUBOS SOLDADOS CUADRADOS

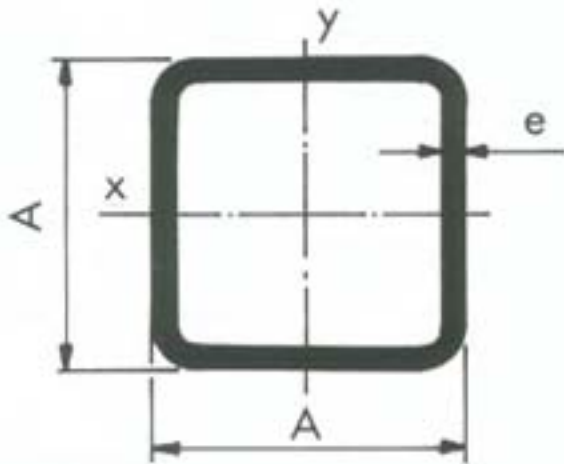

MATERIAL UTILIZADO: Fleje de acero.

- Laminado en caliente y decapado.
- Laminado en frío.
- Galvanizado.

NORMAS DE FABRICACIÓN:

- UNE - EN 10305 - 5

CALIDAD DEL MATERIAL:

A determinar por el cliente.

GAMA DE FABRICACIÓN

DIMENSIONES (mm.) A x A	e (mm.)						
	0,8	1	1,2	1,5	2	2,5	3
PESO POR METRO EN KILOS							
20 x 20	0,481	0,595	0,706	0,868	1,124	1,363	
25 x 25	0,607	0,752	0,895	1,103	1,438	1,756	
30 x 30	0,732	0,909	1,083	1,339	1,752	2,149	2,392
35 x 35		1,066	1,271	1,574	2,066	2,541	2,863
40 x 40		1,223	1,460	1,810	2,380	2,934	3,334
45 x 45		1,380	1,648	2,045	2,694	3,326	3,805
50 x 50			1,836	2,281	3,008	3,719	4,276
55 x 55				2,516	3,322	4,111	4,747
60 x 60				2,752	3,636	4,504	5,218
70 x 70				3,223	4,264	5,289	6,160

TUBOS SOLDADOS RECTANGulares

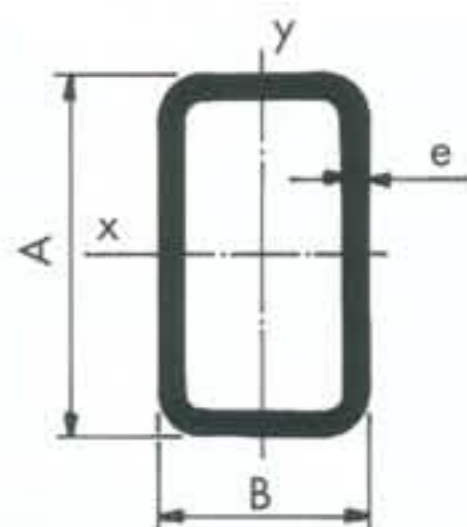

MATERIAL UTILIZADO: Fleje de acero.

- Laminado en caliente y decapado.
- Laminado en frío.
- Galvanizado.

NORMAS DE FABRICACIÓN:

- UNE - EN 10305 - 5

CALIDAD DEL MATERIAL:

A determinar por el cliente.

TUBOS SOLDADOS RECTANGulares

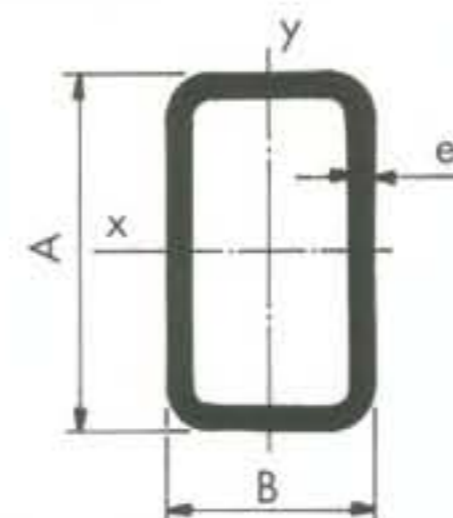

MATERIAL UTILIZADO: Fleje de acero.

- Laminado en caliente y decapado.
- Laminado en frío.
- Galvanizado.

NORMAS DE FABRICACIÓN:

- UNE - EN 10305 - 5

CALIDAD DEL MATERIAL:

A determinar por el cliente.

GAMA DE FABRICACIÓN

DIMENSIONES (mm.) A x B	e (mm.)						
	0,8	1	1,2	1,5	2	2,5	3
	PESO POR METRO EN KILOS						
25 x 15	0,481	0,595	0,706	0,868	1,124		
30 x 10	0,481	0,595	0,706	0,868	1,124		
30 x 15	0,544	0,674	0,800	0,986	1,281		
30 x 20	0,607	0,752	0,895	1,103	1,438	1,756	
30 x 25	0,670	0,831	0,989	1,221	1,595	1,953	
35 x 10	0,544	0,674	0,800	0,986	1,281		
35 x 15	0,607	0,752	0,895	1,103	1,438		
35 x 20	0,670	0,831	0,989	1,221	1,595	1,953	
35 x 25	0,732	0,909	1,083	1,339	1,752	2,149	
35 x 30	0,795	0,988	1,177	1,457	1,909	2,345	2,627
40 x 10	0,607	0,752	0,895	1,103	1,438		
40 x 15	0,670	0,831	0,989	1,221	1,595		
40 x 20	0,732	0,909	1,083	1,339	1,752	2,149	2,392
40 x 24				1,433	1,878	2,306	
40 x 25	0,795	0,988	1,177	1,457	1,909	2,345	2,627
40 x 30		1,066	1,271	1,574	2,066	2,541	2,863
45 x 25	0,858	1,066	1,271	1,574	2,066	2,541	2,863
45 x 35		1,223	1,460	1,810	2,380	2,934	3,334
50 x 10	0,732	0,909	1,083	1,339	1,752		
50 x 15		0,988	1,177	1,457	1,909		
50 x 20		1,066	1,271	1,574	2,066	2,541	
50 x 25		1,145	1,366	1,692	2,223	2,738	3,098

GAMA DE FABRICACIÓN

DIMENSIONES (mm.) A x B	e (mm.)						
	0,8	1	1,2	1,5	2	2,5	3
	PESO POR METRO EN KILOS						
50 x 30		1,223	1,460	1,810	2,380	2,934	3,334
50 x 35				1,927	2,537	3,129	3,569
50 x 40		1,380	1,648	2,045	2,694	3,326	3,805
60 x 10		1,066	1,271	1,574	2,066		
60 x 15			1,366	1,692	2,223	2,738	
60 x 20			1,460	1,810	2,380	2,934	3,334
60 x 25			1,554	1,927	2,537	3,129	3,569
60 x 30				2,045	2,694	3,326	3,805
60 x 40				2,281	3,008	3,719	4,276
60 x 50				2,516	3,322	4,111	4,747
70 x 20				2,045	2,694	3,326	3,805
70 x 30				2,281	3,008	3,719	4,276
70 x 40				2,516	3,322	4,111	4,747
70 x 50				2,752	3,636	4,504	5,218
80 x 20				2,281	3,008	3,719	4,276
80 x 30				2,516	3,322	4,111	4,747
80 x 40				2,752	3,636	4,504	5,218
80 x 50				2,987	3,950	4,896	5,689
80 x 60				3,223	4,264	5,289	6,160
90 x 30				2,752	3,636	4,504	5,218
90 x 40				2,987	3,950	4,896	5,689
90 x 50				3,223	4,264	5,289	6,160
90 x 60				3,458	4,578	5,681	6,631
100 x 20				2,752	3,636	4,504	5,218
100 x 30				2,987	3,950	4,896	5,689
100 x 40				3,223	4,264	5,289	6,160
100 x 50				3,458	4,578	5,681	6,631

TUBOS SOLDADOS REDONDOS

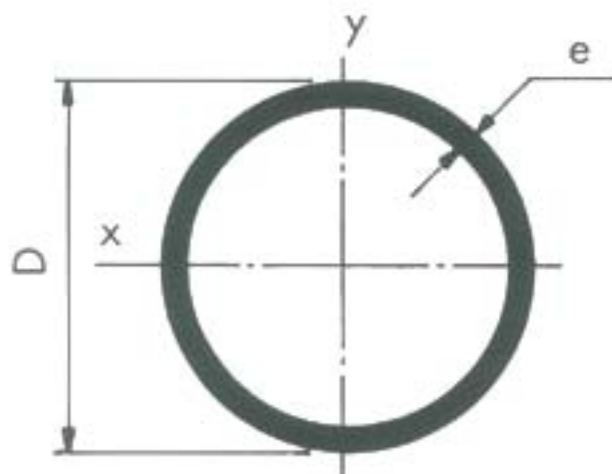

MATERIAL UTILIZADO: Fleje de acero.

- Laminado en caliente y decapado.
- Laminado en frío.
- Galvanizado.

NORMA DE FABRICACIÓN:

- UNE - EN 10305 - 3

CALIDAD DEL MATERIAL:

A determinar por el cliente.

GAMA DE FABRICACIÓN

DIMENSIONES (mm.) D	e (mm.)						
	0,8	1	1,2	1,5	2	2,5	3
PESO POR METRO EN KILOS							
25	0,477	0,592	0,704	0,869	1,134	1,387	
30	0,576	0,715	0,852	1,054	1,381	1,695	1,998
32	0,616	0,765	0,911	1,128	1,480	1,819	2,146
35		0,838	1,000	1,239	1,628	2,004	2,368
38		0,912	1,089	1,350	1,776	2,189	2,589
40		0,962	1,148	1,424	1,874	2,312	2,737
42		1,011	1,207	1,498	1,973	2,435	2,885
45		1,085	1,296	1,609	2,121	2,620	3,107
48		1,159	1,385	1,720	2,269	2,805	3,329
50		1,208	1,444	1,794	2,368	2,929	3,477
52			1,503	1,868	2,466	3,052	3,625
55				1,979	2,614	3,237	3,847
59				2,127	2,811	3,483	4,143
60				2,164	2,861	3,545	4,217
70				2,534	3,354	4,162	4,957
76					3,650	4,532	5,401
77					3,699	4,593	5,475
90					4,340	5,395	6,437